

MITX-CFLO SERIES

INTEL® CNVi SUPPORT FOR FASTER WI-FI

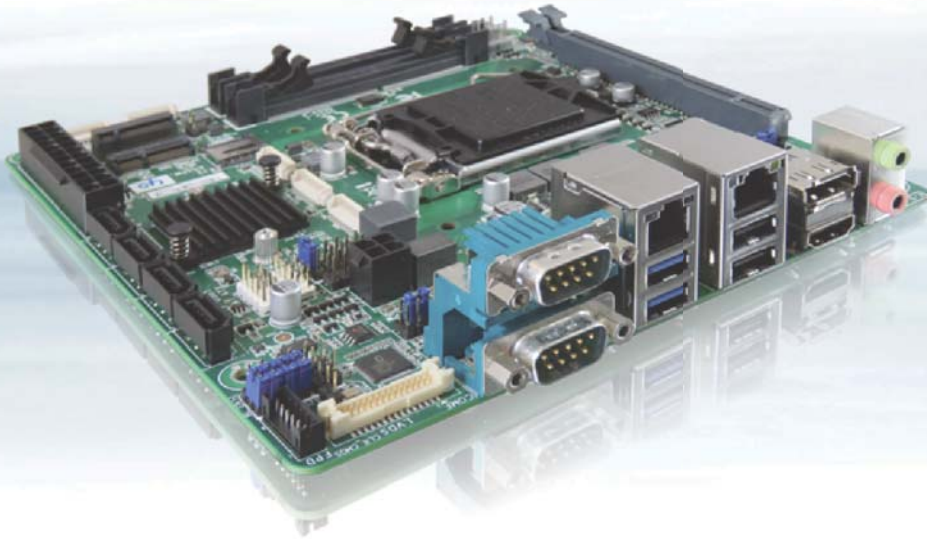

Ordered & Served at
Kontron Asia

MINI-ITX INDUSTRIAL MOTHERBOARD WITH 9TH / 8TH GEN INTEL® CORE™ / CELERON® S-SERIES CPU

- ▶ 1x LVDS, 1x DP++, 1x HDMI 2.0 for video output
- ▶ 2x GbE LAN for Ethernet
- ▶ 2x USB 3.0, 6x USB 2.0, 2x RS232/422/485, 4x RS232, 8-bit DIO, 1x I2C for peripherals
- ▶ 4x SATA 3.0 for storage
- ▶ 1x M.2 Key M, 1x M.2 Key B, 1x M.2 Key E, 1x PCIe x16 for expansion

MITX-CFLO SERIES

MINI-ITX INDUSTRIAL MOTHERBOARD WITH 9TH / 8TH GEN INTEL® CORE™ / CELERON® S-SERIES PROCESSORS

MITX-CFLO Series, a Mini-ITX industrial motherboard powered by 9th / 8th Generation Intel® Core™ / Celeron® S-Series Processors, is designed for enhanced embedded applications in infotainment, industrial automation and process control segments.

has four SATA 3.0 sockets, one PCIe x16 slot, one M.2 Key M socket, one M.2 Key B socket and one M.2 Key E socket for great storage and expansion possibilities. The M.2 Key E socket support Intel® CNVi technology, providing faster Wi-Fi speeds for IoT-connected applications.

In addition to a variety of peripheral interfaces, MITX-CFLO Series

▶ PRODUCT HIGHLIGHTS

- ▶ 9th Gen Intel® Core™ S-Series (LGA1151 socket, up to 65 W TDP)
- ▶ 8th Gen Intel® Core™ / Celeron® S-Series (LGA1151, up to 65 W)
- ▶ Intel® Q370 / H310 Chipset
- ▶ 2x DDR4 SO-DIMM memory socket
- ▶ 1x LVDS, 1x DP++, 1x HDMI 2.0 for video output
- ▶ 2x GbE LAN for Ethernet
- ▶ 2x USB 3.0, 6x USB 2.0 for USB device connection
- ▶ 2x RS232/422/485, 4x RS232 for serial device connection
- ▶ 8-bit DIO for device / signal control
- ▶ 4x SATA 3.0 for storage
- ▶ 1x M.2 Key M, 1x M.2 Key B, 1x M.2 Key E for SSD & wireless
- ▶ 1x PCIe x16 for application-specific expansion
- ▶ TPM 2.0 support



▶ BLOCK DIAGRAM

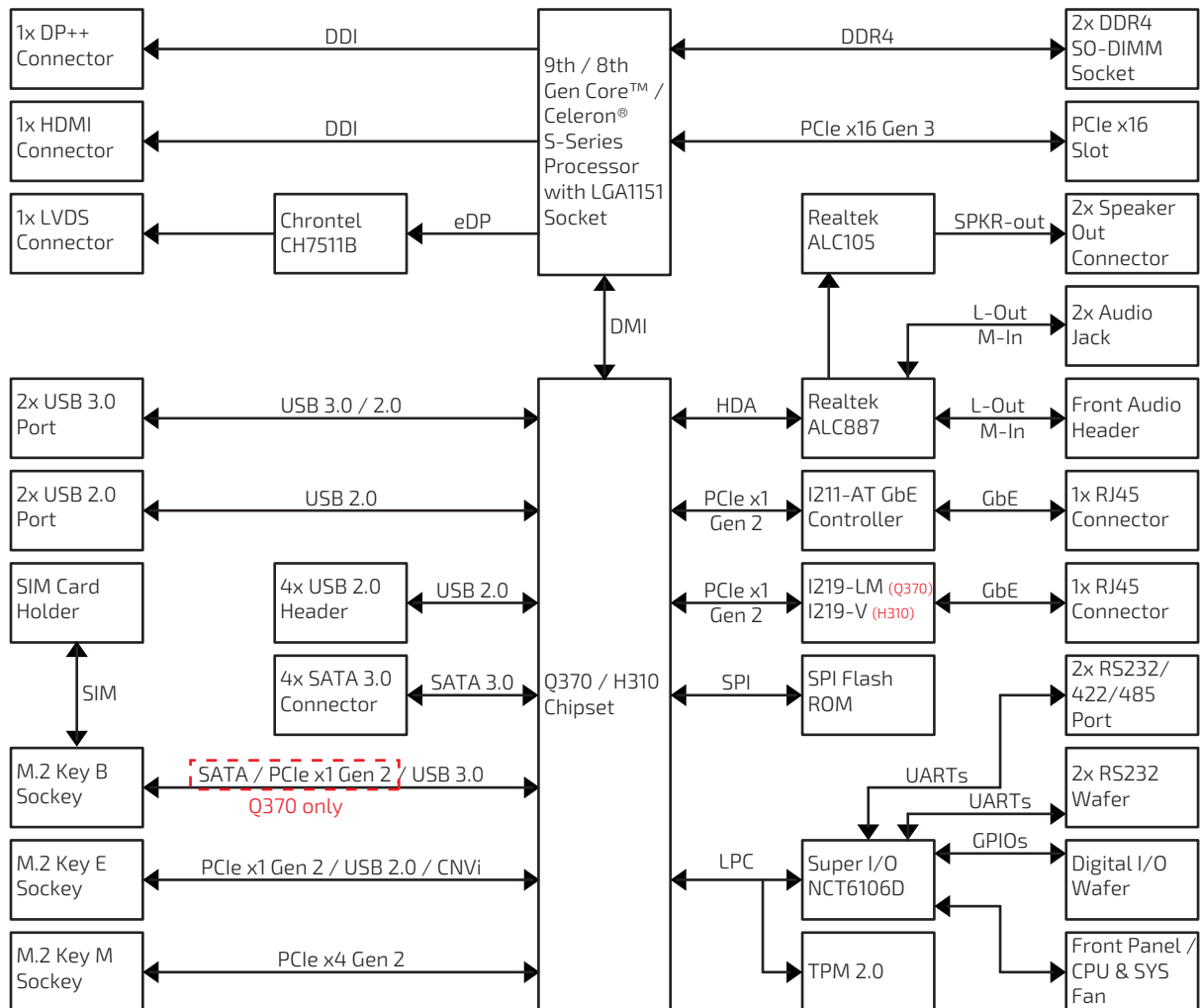

► TECHNICAL INFORMATION

SYSTEM	PROCESSOR CHIPSET MEMORY	9th Generation Intel® Core™ S-Series (LGA1151 socket, up to 65 W TDP) 8th Generation Intel® Core™ S-Series (LGA1151 socket, up to 65 W TDP) 8th Generation Intel® Celeron® S-Series (LGA1151 socket, up to 65 W TDP) Intel® Q370 Intel® H310 2x DDR4 2666 SO-DIMM up to 32 GByte (Core™ i9 / i7 / i5) 2x DDR4 2400 SO-DIMM up to 32 GByte (Core™ i3 / Celeron®)
VIDEO	GRAPHICS DISPLAY INTERFACE MULTIPLE DISPLAY	Intel® UHD Graphics 630 (Core™) Intel® UHD Graphics 610 (Celeron®) 1x LVDS (24-bit, 2-ch, 1920 x 1200 @ 60 Hz) 1x DP++ (on rear, 4096 x 2304 @ 60 Hz) 1x HDMI 2.0 (on rear, 3840 x 2160 @ 60 Hz) Triple (Q370) Dual (H310)
AUDIO	AUDIO CODEC AUDIO INTERFACE	Realtek ALC887 2x Speaker-out (3 W, by header) 2x Line-out (1x on rear, 1x by header) 2x Mic-in (1x on rear, 1x by header)
NETWORK CONNECTION	ETHERNET	2x GbE LAN (RJ45, 1x Intel® I211-AT, 1x Intel® I219-LM (Q370) / I219-V (H310))
PERIPHERAL CONNECTION	USB SERIAL PORT OTHER I/Os	2x USB 3.0 (Type A on rear) 6x USB 2.0 (2x Type A on rear, 4x by header) 2x RS232/422/485 (DB9 on rear) 4x RS232 (by header) 1x 8-bit DIO (by header) 1x I2C (by header)
STORAGE & EXPANSION	SATA M.2 PCIe SIM CARD HOLDER	4x SATA 3.0 1x M.2 Key M (type 2242 / 2280, mixed w/ PCIe x4) 1x M.2 Key B (type 2242 / 3042 / 2280, w/ SATA / PCIe x1 / USB 3.0 for Q370) 1x M.2 Key B (type 2242 / 3042 / 2280, w/ USB 3.0 for H310) 1x M.2 Key E (type 2230, w/ PCIe x1 / USB 2.0, CNVi support) 1x PCIe x16 (one x16 signal for H310 / one x16 or two x8 signal for Q370) 1x Micro SIM Card Cage (connected to M.2 Key B)
POWER	CONNECTOR & INPUT VOLTAGE	2x12-pin ATX connector (DC +5 V / +12 V / -12 V / +3.3 V / 5 VSB) 2x2-pin ATX connector (DC 12 V)
FIRMWARE	BIOS WATCHDOG H/W MONITOR REAL TIME CLOCK TPM	AMI uEFI BIOS w/ 128 Mb SPI Flash Programmable WDT to generate system reset event Input & Core Voltages, CPU & System Temperatures Chipset integrated RTC TPM 2.0 support (Infineon SLB9665)
SYSTEM CONTROL & MONITORING	BUTTON, SWITCH & INDICATOR FP HEADER	1x Standby LED (onboard) 1x Boot LED (onboard) 1x Header for Reset button, HDD LED & External Speaker 1x Header for Power button, Power LED & SM bus 1x Header for Volume Control 1x Header for Chassis Intrusion Detection
COOLING	FAN	1x Wafer for CPU Smart Fan 1x Wafer for System Smart Fan
SOFTWARE	OS SUPPORT	Windows 10
MECHANICAL	DIMENSIONS (L x W)	Mini-ITX (170 mm x 170 mm / 6.70" x 6.70")
ENVIRONMENTAL	OPERATION TEMPERATURE STORAGE TEMPERATURE HUMIDITY	0 °C ~ 60 °C / 32 °F ~ 140 °F (Standard) -20 °C ~ 80 °C / -4 °F ~ 176 °F (Standard) 0 % ~ 95 %
CERTIFICATION	EMC & SAFETY	CE Class A, FCC Class A

► ORDERING INFORMATION

ARTICLE	DESCRIPTION
MITX-CFLO	Intel® H310 Chipset, 2x GbE (Intel® I211-AT + Intel® I219-V), 1x M.2 key B w/ USB 3.0 signal
MITX-CFL1	Intel® Q370 Chipset, 2x GbE (Intel® I211-AT + Intel® I219-LM), 1x M.2 Key B w/ SATA / PCIe x1 / USB 3.0 signal